

REV	DATE	ECN NO.	MODIFICATION	APPROVER
A	2016/04/08		NEW	Jason

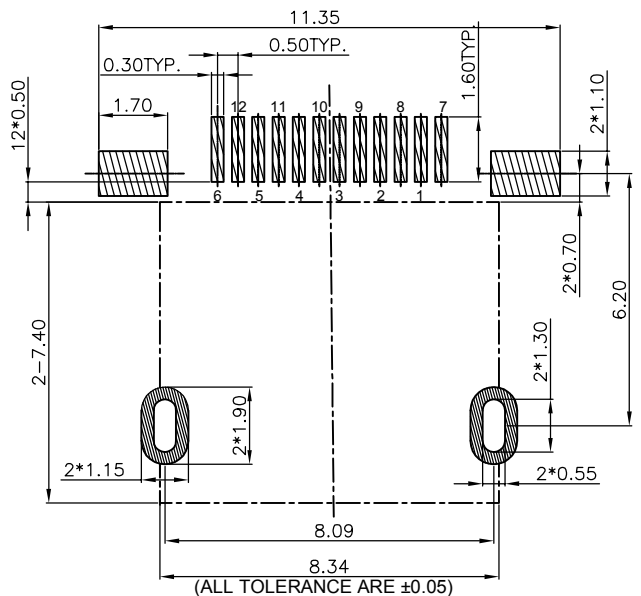

RECOMMENDED PCB LAYOUT

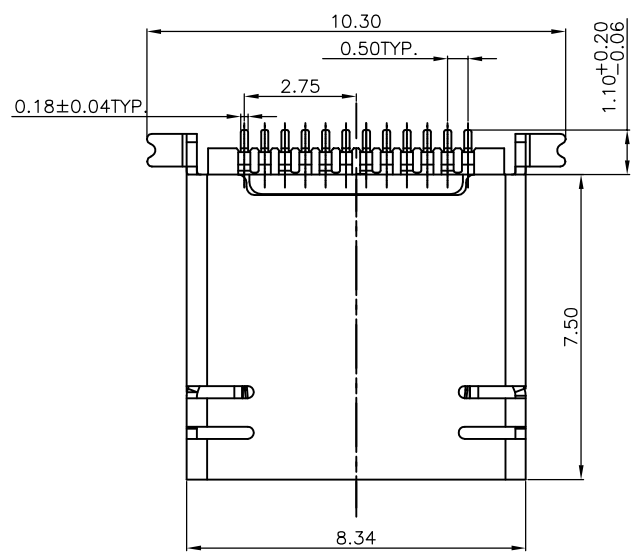
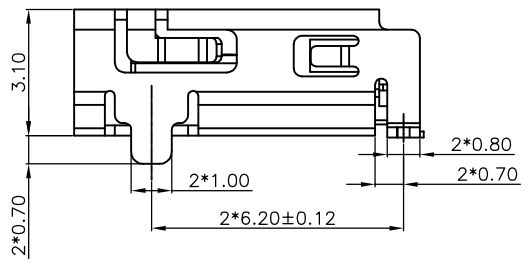
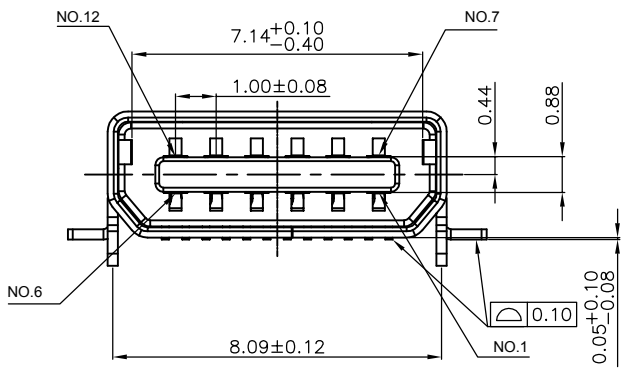
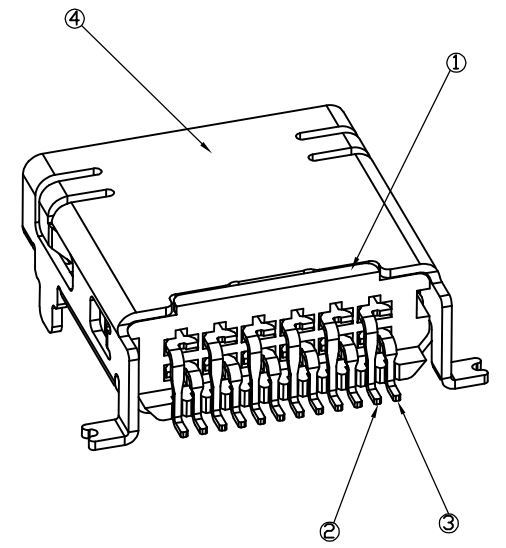

- NOTE:
- 1.Insert and extract at the speed of 25mm/minute
Plug insertion force:2.40kg MAX, extraction force:0.2kg MIN.
 - 2.Durability:5000 cycles.
 - 3.Insulation resistance: 100MΩ Min. at 500 V DC(After Testing)
 - 4.contact resistance: 50mΩ Max.
 - 5.Withstanding voltage:500V(r.m.s.)AC for one minute
 - 6.rating current:0.5A
 - 7.Operating temperature: -40℃~ +85℃
 - 8.Storage temperature: -40℃~ +85℃
 - 9.Ambient Humidity Range :85% R.H. Max

GENERAL TOLERANCE			UNITS mm	NAME: MINI USB 12P		ATOM [®] 深圳市爱特姆科技有限公司 SHENZHEN ATOM TECHNOLOGY CO.,LTD.	
SELECT	✓			MAT'L	PART NO: USB112FD-C1013206		TITLE: MINI USB 12P FEMALE SMT 前插后贴
DN.	TOL	1 2 3	FINISH		APPD:		DWG NO. ATOM-A02978
X.XXX	±0.10	±0.05 ±0.15		Q'TY	CHKD:		SCALE SHEET REV
X.XX	±0.15	±0.13 ±0.25	DR: JACK		1:1		1/1 A
X.X	±0.20	±0.25 ±0.5					
X.	±0.30	±0.30 ±1.00					
ANGLE	±2°						